

Middle East respiratory syndrome coronavirus

Laboratory case definition

The Public Health Laboratory Network (PHLN) has developed standard case definitions for the diagnosis of key diseases in Australia. This document contains the laboratory case definition for *Middle East respiratory syndrome coronavirus*.

Authorisation: PHLN

1 PHLN Summary Laboratory Definition

1.1 Condition:

Middle East Respiratory Syndrome coronavirus (MERS-CoV) infection

1.1.1 WHO laboratory-confirmed criteria

A positive PCR result for at least two different specific targets on the MERS-CoV genome

OR

One positive PCR result for a specific target on the MERS-CoV genome and an additional different PCR product sequenced, confirming relatedness to known sequences of MERS-CoV.

A case with a positive PCR result for a single specific target without further testing, but with a history of potential exposure and consistent clinical signs, is considered a probable case.

At present, positive serology (MERS-CoV-specific antibodies) results in the absence of PCR testing or sequencing are considered probable cases of MERS-CoV infection if they meet the clinical case definition.

2 The disease

2.1 Infectious agent

Coronaviruses are a large and diverse family of viruses that include viruses that are known to cause illness in humans and animals. Four human *coronaviruses* (hCoV) are known causes of respiratory infections of mild to moderate severity. These include the *betacoronaviruses* hCoV-OC43 and hCoV-HKU1, and the *alphacoronaviruses* hCoV-229E and hCoV-NL63. *Severe acute respiratory syndrome coronavirus* (SARS-CoV) and MERS-CoV are *betacoronaviruses* that can cause severe respiratory infection. MERS-CoV is genetically distinct from SARS-CoV.

2.2 Reservoir

It is likely that the MERS-CoV has come from an animal source. MERS-CoV has been found in camels in Qatar and a bat in Saudi Arabia. Sera from camels in a few other countries (but not Australia) have also tested positive for antibodies to MERS-CoV, indicating they were previously infected with MERS-CoV or a closely related virus. However, it is not known if camels are the source of the virus for human infections. More information is needed to identify the possible role that camels, bats, and other animals may play in MERS-CoV transmission.

2.3 Mode of transmission

The mode or modes of transmission of MERS-CoV are not fully known.

There have been some cases with a strong history of exposure to camels, including at least one cluster where the camels also tested seropositive, but there have been many sporadic cases with no history of prior exposure to camels or other animals. Analysis of genetic sequence data suggests multiple independent introductions into human populations, rather than from a single zoonotic event.

Although there have been multiple clusters of cases in which human-to-human transmission has occurred, sustained human-to-human transmission has not been observed. Clusters of human-to-human transmission have been observed in healthcare facilities, among family members and between co-workers. However, the mechanism by which transmission occurred in all of these cases, whether respiratory (e.g. coughing, sneezing) or direct physical contact with the patient or contamination of the environment by the patient, is unknown.

Infection control recommendations for managing suspect, probable and confirmed cases are consistent with those recommended for SARS-CoV. As information becomes available, these recommendations will be re-evaluated and updated as needed.

2.4 Incubation period

From 2 to 14 days, with a median of ~5 days.

2.5 Infectious period

The duration of infectivity following MERS-CoV infection is unknown. Standard precautions should always be applied; additional isolation precautions should be used during the duration of symptomatic illness and continued for at least 24 hours after the resolution of symptoms.

Given that little information is currently available on viral shedding and the potential for transmission of MERS-CoV, testing for viral shedding should assist the decision making when readily available. Individual patient factors (e.g. age, immune status, other co-morbidities) should also be considered in situations where there is concern that a patient may be shedding the virus for prolonged periods.

2.6 Clinical presentation and outcome

Clinical presentation ranges from asymptomatic to severe pneumonia with acute respiratory distress syndrome and multi-organ failure. Nearly all symptomatic patients have presented with respiratory symptoms and one third of patients have had gastrointestinal symptoms.

Typically, the disease starts with fever and cough, chills, sore throat, myalgia and arthralgia, followed by dyspnoea, and rapidly progresses to pneumonia, often requiring mechanical ventilation and other organ support.

The case fatality rate for confirmed cases is ~30% but this may decrease as mild or asymptomatic cases are identified during contact tracing of known cases.

2.7 Persons at increased risk of disease

Cases who are elderly, immunocompromised or with co-morbidities have an increased mortality rate.

2.8 Disease occurrence and public health significance

There have been no confirmed MERS-CoV cases reported in Australia to date. MERS-CoV is also not a national notifiable disease at present, but is notifiable in some States such as Western Australia.

As of 17th July 2014, 834 laboratory-confirmed cases of human infection with MERS-CoV have been reported to WHO, including at least 288 related deaths.

At the time of writing, the affected countries in the Middle East include Iran, Jordan, Kuwait, Lebanon, Oman, Qatar, Saudi Arabia (KSA), United Arab Emirates (UAE) and Yemen; in Africa: Algeria, Egypt and Tunisia; in Europe: France, Germany, Greece, Italy, the Netherlands and the United Kingdom; in Asia: Malaysia and Philippines; and in North America: the United States of America (USA).

WHO expects that additional cases of MERS-CoV infection will be reported from the Middle East, and that it is likely that cases will continue to be exported to other countries by tourists, travellers, guest workers or pilgrims who might acquire infection following exposure to an animal (for example, while visiting farms or markets) or human source (possibly in a health care setting). Until more is understood about mode of transmission and risk factors for infection, cases resulting from zoonotic transmission are likely to continue to occur, and may seed limited community transmission within household and possibly significant hospital-associated outbreaks.

3 Clinical case definitions

3.1 Confirmed case

- A confirmed case requires laboratory definitive evidence of infection with MERS-CoV

3.2 Probable case

- A person with an acute respiratory infection with clinical, radiological, or histopathological evidence of pulmonary parenchymal disease (e.g. pneumonia or Acute Respiratory Distress Syndrome (ARDS)); AND
- Either no possibility of laboratory confirmation for MERS-CoV because the patient or samples are not available for testing; or results of laboratory testing awaited AND
- Close contact with a laboratory-confirmed case (see the Contact Management section below for guidance on identifying close contacts).

Notes:

- Transiting through an international airport (<24 hours stay, remaining within the airport) in the Middle East is not considered to be risk factor for infection.
- Countries in the Middle East and immediate surrounding areas may be defined as:
- Bahrain, Iraq, Iran, Israel, Jordan, Kuwait, Lebanon, Oman, Palestinian territories, Qatar, Saudi Arabia, Syria, the United Arab Emirates (UAE), and Yemen.
- Laboratory definitive evidence: to consider a case as laboratory-confirmed, one of the following conditions must be met: (WHO MERS-CoV testing algorithm)
- A positive MERS-CoV PCR result (note that WHO currently recommend PCR for at least two different specific targets on the MERS-CoV genome, or alternatively one positive PCR result for a specific target on the MERS-CoV genome and an additional different PCR product sequenced, confirming relatedness to known sequences of MERS-CoV. While this is endorsed as good practice for Australia to provide confirmation of initial cases it is not considered practical as an ongoing routine diagnostic approach.

3.3 Suspect case/Patient under investigation

MERS-CoV testing should be considered for:

- Individuals with pneumonia or pneumonitis and history of travel to, or residence in, the Middle East, in the 14 days before illness onset; OR
- Individuals with pneumonia or pneumonitis and history of contact with those mentioned above in the 14 days before illness onset.
- Healthcare workers with pneumonia or pneumonitis, who have been caring for patients with severe acute respiratory infections, particularly patients requiring intensive care, without regard to place of residence or history of travel, where another cause has not been confirmed.

Note: Also consider in laboratory workers who have handled clinical specimens from confirmed MERS-CoV cases without adequate infection control precautions.

4 Laboratory testing

4.1 Testing guidelines

Patients to be considered for MERS-CoV testing are described under the Suspect case/Patient under investigation case definition (above).

Transmission-based contact and airborne precautions must be used when collecting respiratory specimens. These are described in NHMRC: Australian Guidelines for the Prevention and Control of Infection in Healthcare – 2010 (particularly section B2.4), and include:

- Contact precautions, including close attention to hand hygiene
- Airborne transmission precautions, including routine use of a P2 respirator, disposable gown, gloves, and eye protection when entering a patient care area
- A requirement for negative pressure air-handling
- Place clearly labeled specimens for transport in a biohazard specimen bag (leak-proof specimen bags that have a separate sealable pocket for the specimen) with a clearly written request form
- Deliver all specimens by hand, do not use pneumatic-tube specimen transport systems
- Notify the receiving laboratory as soon as possible that a specimen is being transported.

See Appendix 1 for requirements for specimen handling and transport to the laboratory.

4.2 Samples suitable for testing

4.2.1 Respiratory samples

Upper respiratory tract samples

Nasopharyngeal swab and/or oropharyngeal swab

- nasopharyngeal: insert a swab into each nostril parallel to the palate, leave the swab in place for a few seconds to absorb secretions
- oropharyngeal: swab the tonsillar beds, avoiding the tongue
- place swabs back into the accompanying transport media

Nasal wash/aspirates

- collect 2-3 mL into a sterile, leak-proof, screw-top dry sterile container

Lower respiratory tract samples

Bronchoalveolar lavage, tracheal aspirate, pleural fluid

- collect 2-3 mL into a sterile, leak-proof, screw-top sputum collection cup or dry sterile container

Sputum

- patient should rinse his/her mouth with water before collection
- expectorate deep cough sputum directly into a sterile, leak-proof, screw-top dry sterile container

There is now increasing evidence that lower respiratory tract specimens such as contain the highest viral loads, therefore, lower respiratory tract specimens should be collected where possible. Repeat testing (especially of lower respiratory tract specimens) in compatible cases should be performed if initial results are negative.

4.2.2 Serology

Serum should be collected during the acute phase of the illness (preferably within the first 7 of symptom onset), stored, and tested in parallel with a convalescent serum collected 3 or more weeks after acute sample collection.

If no acute sample was collected, a single serum sample collected 14 or more days after symptom onset may be tested.

At the time of writing, limited indirect fluorescent antibody (IFA) serology is available but only specificity can be established without access to significant numbers of positive sera. Only a single MERS-CoV positive sample has been available for validation purposes thus far. Hence serology should be used sparingly as an adjunct to detection of virus in acute cases. Serology may be useful in cases where MERS-CoV is strongly suspected but non-confirmed with nucleic acid testing (NAT). Collection of paired acute and convalescent sera is recommended. Positive serological test results in the absence of NAT or sequencing are considered probable cases only.

In some other countries neutralization serology tests are used for confirmation purposes. Similar to NAT, a two stage approach using a screening followed by a confirmatory test can be employed. In the absence of positive sera with which to establish, calibrate and control such an assay this approach is not possible in Australia. For screening purposes, an enzyme-immunosorbent assay (ELISA) against recombinant N protein can be used.

4.2.3 Stool

2 – 5 grams of stool (formed or liquid) is collected in a sterile, leak-proof, screw-top dry sterile container.

4.3 Testing of other pathogens

Routine tests for acute pneumonia/pneumonitis should be performed where indicated, including bacterial cultures, acute and convalescent serology, urinary antigen testing and tests for influenza and other respiratory viruses.

4.4 Handling of specimens in the laboratory

Laboratory staff should handle specimens under PC2 and PC3 conditions in accordance with AS/NZS 2243.3:2010 Safety in Laboratories Part 3: Microbiological Safety and Containment. Specimens should be transported in accordance with current regulatory requirements (see Appendix 1 and 2).

4.5 MERS-CoV testing

NAT using reverse-transcriptase polymerase chain reaction (RT-PCR) is the method of choice for detection of MERS-CoV. Currently, four targets may be used for testing:-

- upstream region of the E protein (upE) gene
- open reading frame (ORF) 1a (ORF1a)
- ORF1b
- MERS-CoV specific nucleocapsid (N) protein gene

An algorithm using a screening assay, followed by confirmatory testing is recommended for certainty of diagnosis of the initial cases. For screening purposes, assays targeting the upE gene are appropriate. Confirmatory testing can be performed using an assay targeting the ORF1a (comparable sensitivity to upE gene), ORF1b (which is less sensitive than ORF1a or upE) or N gene. It is recommended that positive screening tests be reported to communicable diseases agencies whilst awaiting confirmatory testing.

Where available, RdRp gene (for the broad detection of *b-coronavirus* clade C) and/or N gene sequencing may also be considered for MERS-CoV confirmation. As the primers for the RdRp sequencing assay are highly conserved, it is not recommended that this assay be used alone for MERS-CoV confirmation, as false positive results may occur from cross-reactions with other *b-coronaviruses*. Further information about laboratory testing is available at (<http://www.virology-bonn.de/index.php?id=40>) and (<http://www.fda.gov/downloads/MedicalDevices/Safety/EmergencySituations/UCM355572.pdf>). Testing algorithms may also need to be revised pending further information about the virus, and the number of specimens received in the laboratory for testing.

Viral culture is generally not performed for routine diagnosis, and should only be attempted in laboratories with appropriate experience and containment facilities. MERS-CoV replication has been previously observed on Vero and LLC-MK2 cells within 5 days of inoculation.

4.6 Quality assurance

In 2013, the RCPA Quality Assurance Programs conducted two novel *coronavirus* (MERS-CoV) surveys under the RCPAQAP Biocsecurity module. As clinical samples, live or inactivated virus, were

not available for testing, each survey contained three simulated specimens generated using recombinant plasmids.

The first survey contained varying concentrations of MERS-CoV E, RdRp, N, ORF1a and ORF1b RNA transcripts, whilst the second survey included MERS-CoV and hCoV-NL63 RNA transcripts. Seven laboratories participated in the survey, using in-house developed NAT and commercial assays. In survey 1, 6 of 7 laboratories were able to detect MERS-CoV. In survey 2, 6 of 7 laboratories were able to detect MERS-CoV, but 4 of 6 laboratories (one laboratory using a commercial assay was not able to detect MERS-CoV or hCoV-NL63) falsely detected MERS-CoV in samples containing hCoV-NL63 transcripts.

Although both surveys were conducted using RNA transcripts generated using recombinant plasmids, they highlighted that cross-reactivity and/or cross-contamination during NAT may be an issue for laboratories testing MERS-CoV.

Appendix 1. Suitable specimens and transport requirements (modified from WHO Laboratory testing for *Middle East Respiratory Syndrome Coronavirus* [available at: (http://who.int/csr/disease/coronavirus_infections/MERS_Lab_recos_16_Sept_2013.pdf?ua=1)])

Specimen type	Transport medium	Transport to laboratory	Dangerous goods shipping category
Sputum	No	4°C (if a delay in testing of > 48 hours, consider freezing and shipping with dry ice)	Biological substance, Category B
Bronchoalveolar lavage	No	4°C (if a delay in testing of > 48 hours, consider freezing and shipping with dry ice)	Biological substance, Category B
Tracheal aspirate	No	4°C (if a delay in testing of > 48 hours, consider freezing and shipping with dry ice)	Biological substance, Category B

Specimen type	Transport medium	Transport to laboratory	Dangerous goods shipping category
Nasopharyngeal aspirate	No	4°C (if a delay in testing of > 48 hours, consider freezing and shipping with dry ice)	Biological substance, Category B
Combined nasopharyngeal/oropharyngeal swabs	Viral transport media	4°C (if a delay in testing of > 48 hours, consider freezing and shipping with dry ice)	Biological substance, Category B
Tissue from biopsy or autopsy including lung	Viral transport media	4°C (if a delay in testing of > 48 hours, consider freezing and shipping with dry ice)	Biological substance, Category B
Serum for serological testing	No	4°C or frozen and shipped on dry ice	Biological substance, Category B

Category B packaging preparation includes: manufacturer's instructions followed, good quality packaging, primary receptacles sealed and leakproof, primary receptacle closures secured with secondary means (optional), multiple fragile primaries wrapped individually, sufficient absorbent inside each secondary, secondary packaging properly sealed and leakproof, primary or secondary receptacle 95 kPa pressure compliant, itemized list of contents between secondary and outer packaging, rigid outer packaging, at least one surface of outer packaging is 100 mm x 100 mm

Figure 1. Packing and labelling of Category B infectious substance

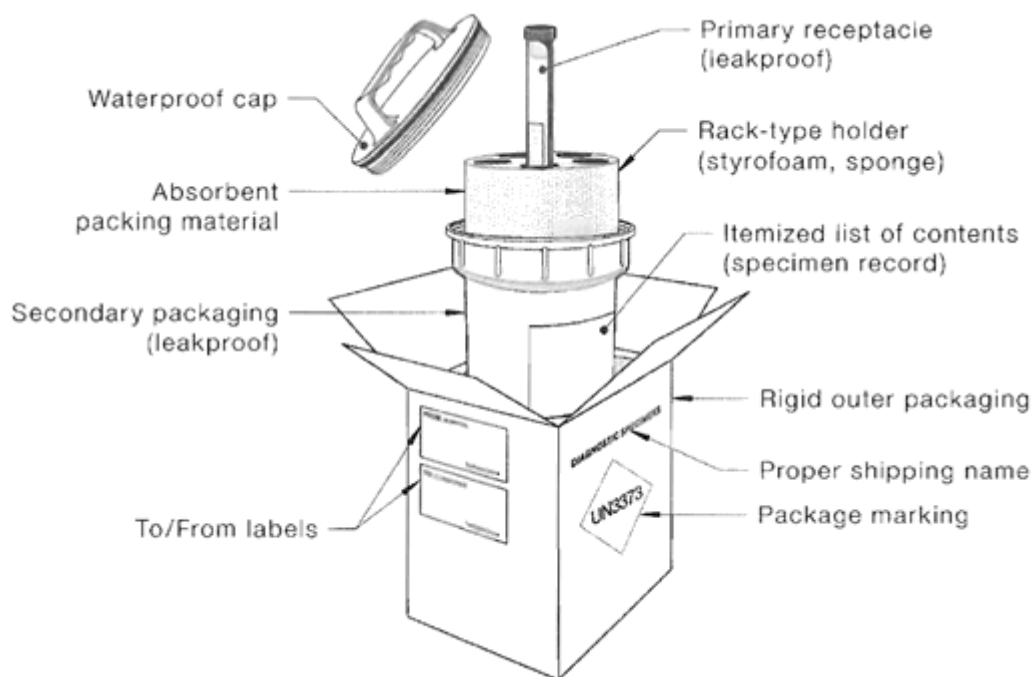

Appendix 2. Guidelines for laboratory staff working with MERS-CoV (modified from [CDC Interim laboratory biosafety guidelines for handling and processing specimens associated with Middle East Respiratory Syndrome Coronavirus – version 2](#))

Activities involving manipulation of potentially infected specimens should be performed in a PC2 facility in a Class 2 biosafety cabinet using PC2 work practice:

- aliquoting and/or diluting specimens
- performing diagnostic tests that do not involve propagation of viral agents in vitro or in vivo
- nucleic acid extraction procedures involving potentially infected specimens

Activities that must be performed in a PC3 facility using PC3 work practices:

- MERS-CoV propagation in cell culture
- initial characterization of viral agents recovered in cultures of MERS-CoV specimens

5 References

1. [The WHO MERS-CoV Research Group. State of knowledge and data gaps of Middle East Respiratory Syndrome Coronavirus \(MERS-CoV\) in humans. PLoS Current Outbreaks 2013; doi: 10.1371/currents.outbreaks.0 bf719e352e7478f8ad85fa30127ddb8.](#)
2. WHO. Laboratory testing for Middle East Respiratory Syndrome Coronavirus. Available at: (http://www.who.int/csr/disease/coronavirus_infections/MERS_Lab_recos_16_Sept_2013.pdf?ua=1)

3. Corman VM, Eckerle I, Bleicker T, et al. [Detection of a novel human coronavirus by real-time reverse-transcription polymerase chain reaction. Euro Surveill 2012; 17:pii=20285.](#)
4. Corman VM, Muller MA, Costabel U, et al. [Assays for laboratory confirmation of novel coronavirus \(hCoV-EMC\) infections. Euro Surveill 2012; 17:pii=20334.](#)
5. Zaki AM, van Boheemen S, Bestebroer TM, et al. Isolation of a novel coronavirus from a man with pneumonia in Saudi Arabia. N Engl J Med 2012; 367: 1814-1820.
6. [CDC. Interim laboratory biosafety guidelines for handling and processing specimens associated with Middle East Respiratory Syndrome Coronavirus – version 2.](#)